

## Angled tubular cable lugs, Cu, 45° angled, standard type

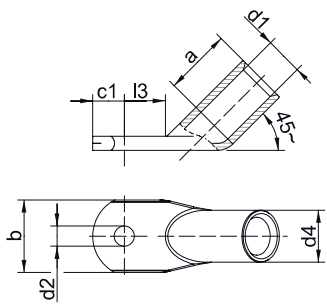

- ▶ For multi-stranded, round conductors e.g. to EN 60228
- ▶ For pre-rounded multi-stranded sector shaped conductors
- ▶ Flat contact surface by special angle pressing technology
- ▶ In combination with EKM 60 ID and EK 30 ID suitable for fine-stranded conductors

### Characteristics

- Simple cable entry due to internal chamfer
- Item identification on cable lug

### Material

- Copper (EN13600)



### Surface

- Tin-plated to protect against corrosion



### Technical instructions

- Tool: see page 1.30
- You will find further information on the cable descriptions in the technical appendix, page i-6
- Sleeves for compacted conductors and sleeves for 3-core and 4-core cables, see chapter „Sleeves for compacted conductors and sector shaped conductors - Cu“



### Additional information

- Possible as a special version with inspection hole on request.  
Part Number appendix „MS“

Nominal cross section mm <sup>2</sup>	Size of bolt dia.	Part No.	Dimension mm							Weight/ 100 pcs. ~ kg	Packing unit/pcs
			d1	a	b	d2	d4	c1	l3		
6	M5	<b>41R545</b>	3.5	9	10	5.5	6.5	7.5	9	0.60	50
	M6	<b>41R645</b>	3.5	9	12	6.4	6.5	7.5	10	0.58	50
	M8	<b>41R845</b>	3.5	9	14	8.4	6.5	10.0	13	0.68	50
	M10	<b>41R1045</b>	3.5	9	17	10.5	6.5	12.0	15	0.70	50
	M12	<b>41R1245</b>	3.5	9	19	13.0	6.5	13.0	17	0.70	50
10	M5	<b>42R545</b>	4.5	10	12	5.5	7.0	6.5	10	0.57	50
	M6	<b>42R645</b>	4.5	10	12	6.4	7.0	6.5	10	0.57	50
	M8	<b>42R845</b>	4.5	10	15	8.4	7.0	10.0	13	0.63	50
	M10	<b>42R1045</b>	4.5	10	17	10.5	7.0	12.0	15	0.68	50
	M12	<b>42R1245</b>	4.5	10	19	13.0	7.0	13.0	18	0.68	50
16	M5	<b>43R545</b>	5.5	13	12	5.5	8.5	7.5	10	1.01	50
	M6	<b>43R645</b>	5.5	13	12	6.4	8.5	7.5	11	1.06	50
	M8	<b>43R845</b>	5.5	13	15	8.4	8.5	10.0	13	1.15	50
	M10	<b>43R1045</b>	5.5	13	17	10.5	8.5	12.0	15	1.09	50
	M12	<b>43R1245</b>	5.5	13	19	13.0	8.5	13.0	18	1.15	50
25	M5	<b>44R545</b>	7.0	15	14	5.5	10.0	7.5	11	1.40	25
	M6	<b>44R645</b>	7.0	15	14	6.4	10.0	7.5	11	1.32	25
	M8	<b>44R845</b>	7.0	15	16	8.4	10.0	10.0	13	1.44	25
	M10	<b>44R1045</b>	7.0	15	18	10.5	10.0	12.0	15	1.49	25
	M12	<b>44R1245</b>	7.0	15	19	13.0	10.0	13.0	18	1.44	25
	M14	<b>44R1445</b>	7.0	15	21	15.0	10.0	14.5	20	1.55	25
35	M6	<b>45R645</b>	8.5	17	17	6.4	12.0	7.5	11	2.05	25
	M8	<b>45R845</b>	8.5	17	17	8.4	12.0	10.0	13	2.20	25
	M10	<b>45R1045</b>	8.5	17	19	10.5	12.0	12.0	15	2.28	25
	M12	<b>45R1245</b>	8.5	17	21	13.0	12.0	13.0	18	2.38	25
	M16	<b>45R1645</b>	8.5	17	26	17.0	12.0	16.0	22	2.40	25

See next page